

ARTIA

ARTIA



An aerial photograph of a lush tropical garden. The scene is dominated by dense greenery, including numerous palm trees and other tropical plants. In the lower right quadrant, a rectangular swimming pool with clear blue water is visible. To the right of the pool, there is a dark metal fence with vertical bars, and behind it, a building with warm interior lights is partially visible. The overall atmosphere is serene and natural.

“La simplicidad es la  
máxima sofisticación”.

*Leonardo da Vinci*





# THE ART *of* NATURE

ARTRA comenzará a construir una historia extraordinaria en el corazón de la Cultura Maya, Tulum, alrededor del arte de la naturaleza que caracteriza al caribe mexicano, fusionando la arquitectura, el diseño disruptivo y el paisaje místico.

ARTRA will begin to build an extraordinary story in the heart of the Mayan Culture, Tulum, around the art of nature that characterizes the Mexican Caribbean, fusing architecture, disruptive design and the mystical landscape.











# UBICACIÓN LOCATION

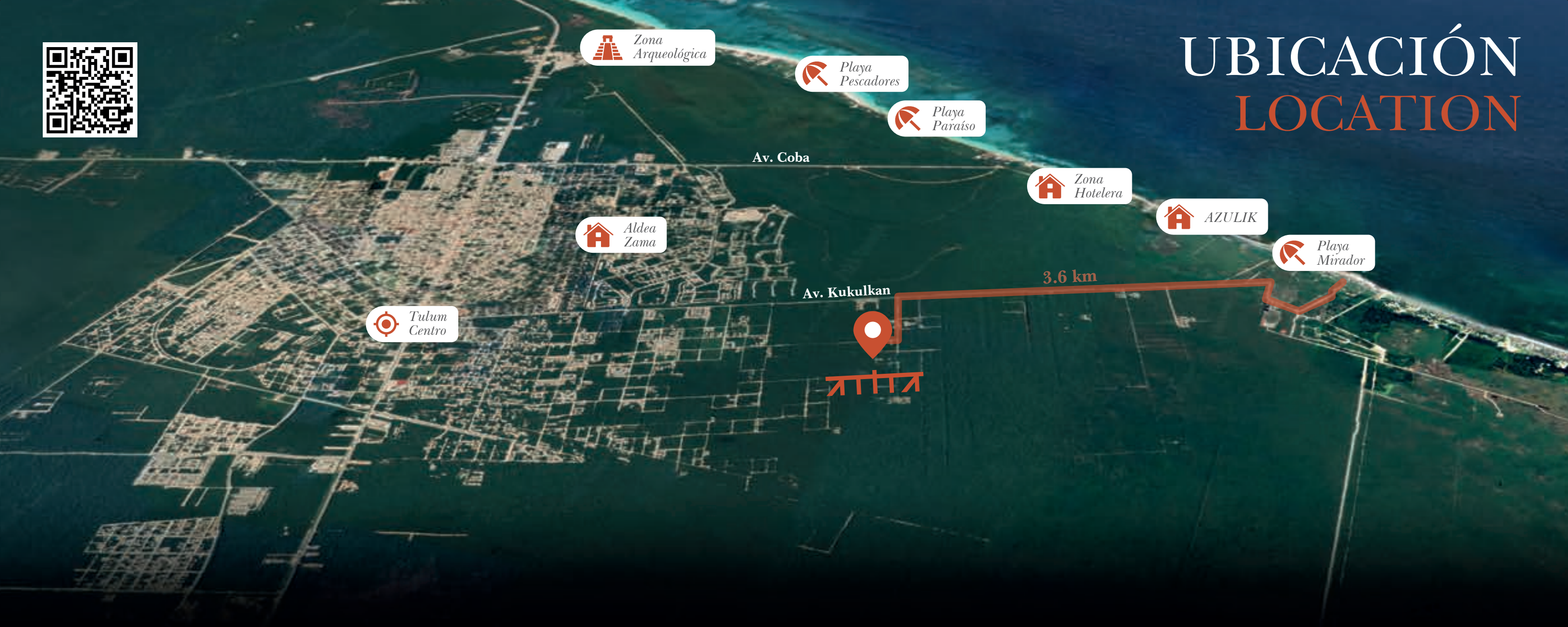

Tulum es incomparable paraíso natural y cultural que hoy en sincronía con la elegancia, se convierte en el marco perfecto para ARTRA. La ubicación brindará además una experiencia completa al ofrecer privacidad para el descanso y al mismo tiempo proximidad y conexión para disfrutar de la Riviera Maya.

Tulum is an incomparable natural and cultural paradise that today, in sync with elegance, becomes the perfect setting for ARTRA. The location will also provide a complete experience by offering privacy for rest and at the same time proximity and connection to enjoy the Riviera Maya.







# DESARROLLO

*el*  
PLAN MAESTRO

+9,000 metros cuadrados  
de magia arquitectónica

112 unidades de lujo

5 tipologías

+13 amenidades para  
transformar el espíritu

*las*  
AMENIDADES

- ① Motor Lobby
- ② Lobby galería
- ③ Galería de arte
- ④ Bistro Bar
- ⑤ Paisajismo
- ⑥ Piscina infinita
- ⑦ Fire Pit
- ⑧ Jacuzzi
- ⑨ Spa
- ⑩ Gimnasio
- ⑪ Piscina “espejo”
- ⑫ Área lounge / Área de descanso
- ⑬ Centro Zen / Área de yoga
- ⑭ Cine

# DEVELOPMENT

*the*  
MASTER PLAN

+9,000 square meters  
of architectural magic

112 luxury units

5 typologies

+13 amenities to  
transform the spirit

*the*  
AMENITIES

- ① Motor Lobby
- ② Galery Lobby
- ③ Art Galery
- ④ Bistro Bar
- ⑤ Landscaping
- ⑥ Infinity pool
- ⑦ Fire Pit
- ⑧ Jacuzzi
- ⑨ Spa
- ⑩ Gym
- ⑪ “Mirror” pool
- ⑫ Lounge area / Rest area
- ⑬ Zen center / Yoga area
- ⑭ Movie theater

















# TIPOLOGÍAS POR DEPARTAMENTO / APARMENT TYPOLOGIES

Edificio 1 y 2 | Nivel 1 / Building 1 & 2 | 1st level

## Garden A



ÁREA INTERIOR / INDOOR AREA  
39.69 M2

ÁREA TERRAZA / TERRACE AREA  
26.56 M2

ÁREA TOTAL / TOTAL AREA  
66.25 M2

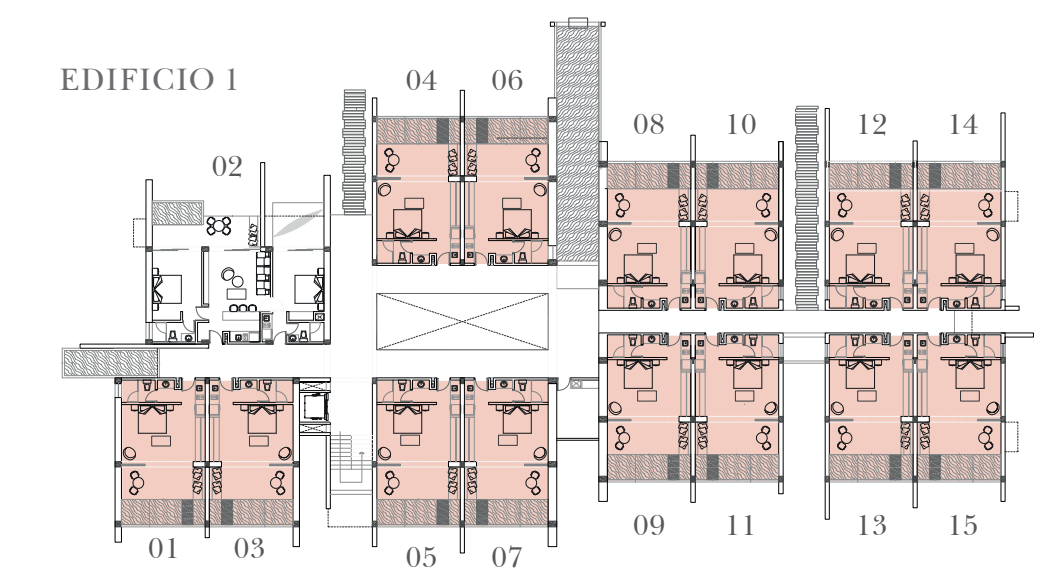
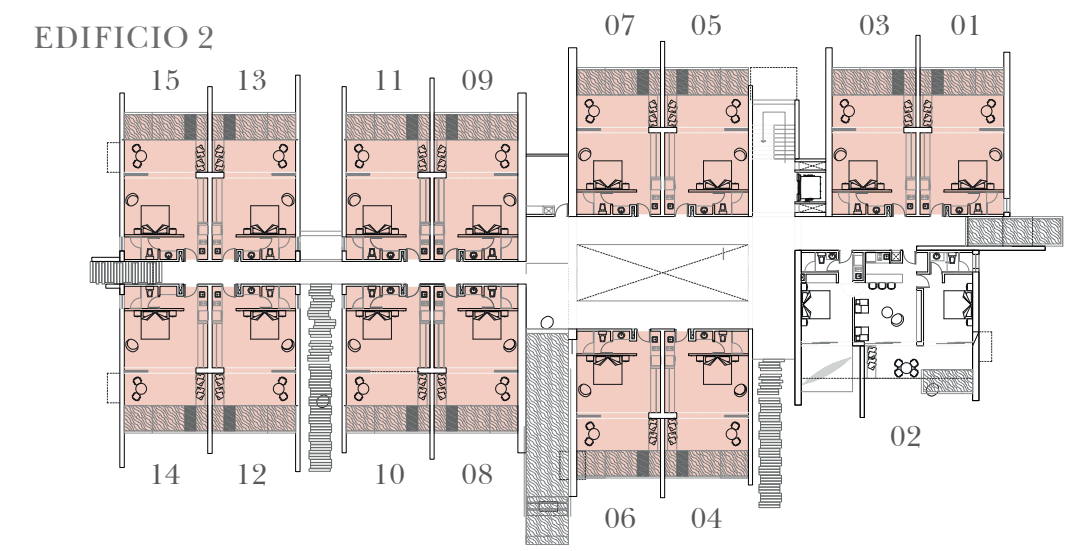
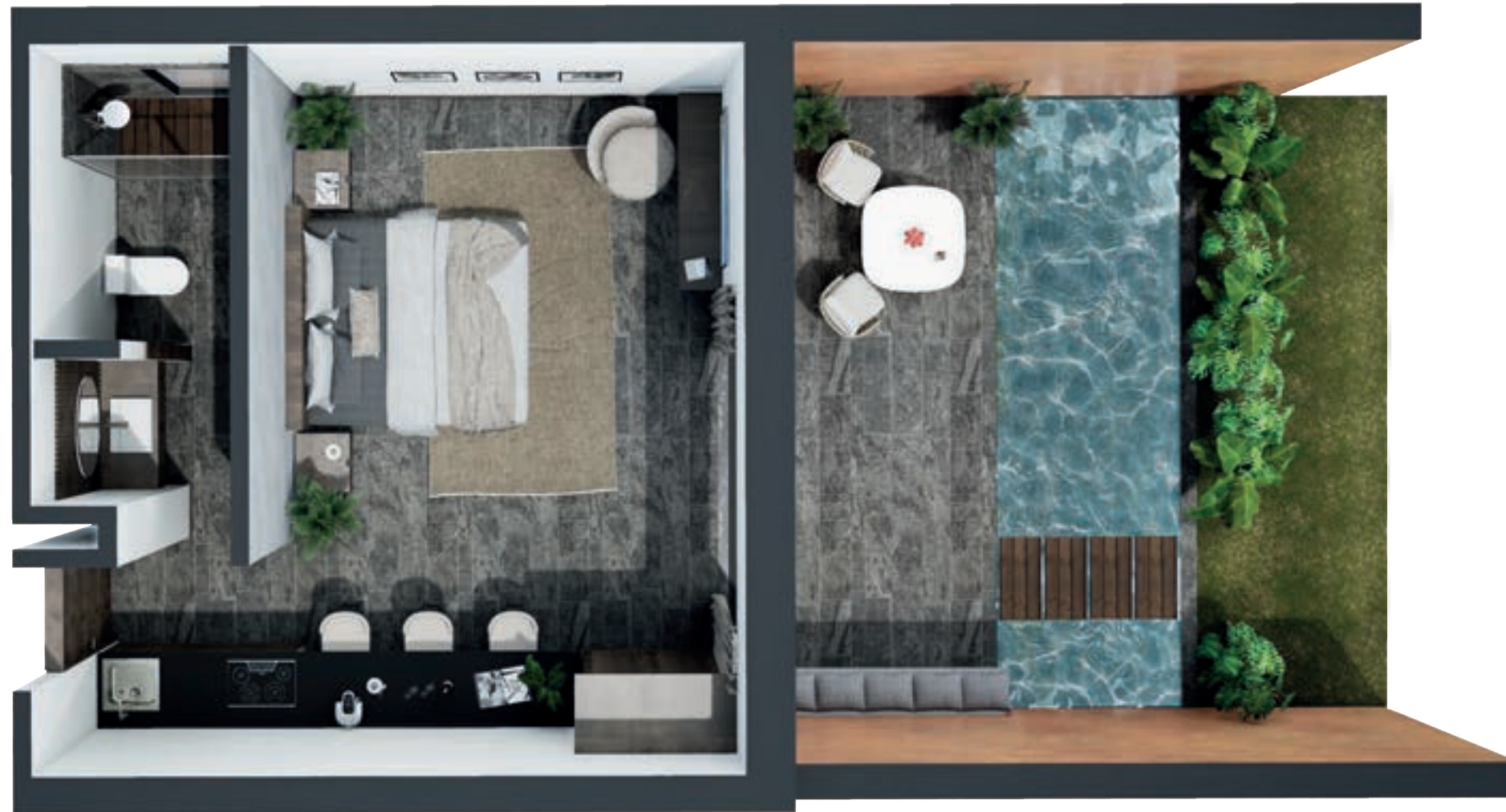

HABITACIONES ROOMS	SALA DE ESTAR LIVING ROOM	BAÑO BATHROOM	COMEDOR DINNIG ROOM	DESAYUNADOR EXTERIOR OUTDOOR BREAKFAST SPOT	DESAYUNADOR INTERIOR INDOOR BREAKFAST SPOT	ALBERCA POOL	CAMASTROS SUNBEDS	COCINA KITCHEN	CUARTO DE LAVADO LAUNDRY ROOM	JACUZZI JACUZZI

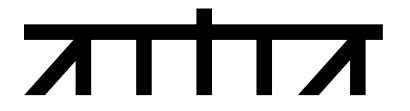



# TIPOLOGÍAS POR DEPARTAMENTO / APARMENT TYPOLOGIES

Edificio 1 y 2 | Nivel 2, 3 y 4 / Building 1 & 2 | 2nd, 3rd & 4th level

# Tipo A

ÁREA INTERIOR / INDOOR AREA  
**39.69 M2**

ÁREA TERRAZA / TERRACE AREA  
**14.4 M2**

ÁREA TOTAL / TOTAL AREA  
**54.09 M2**

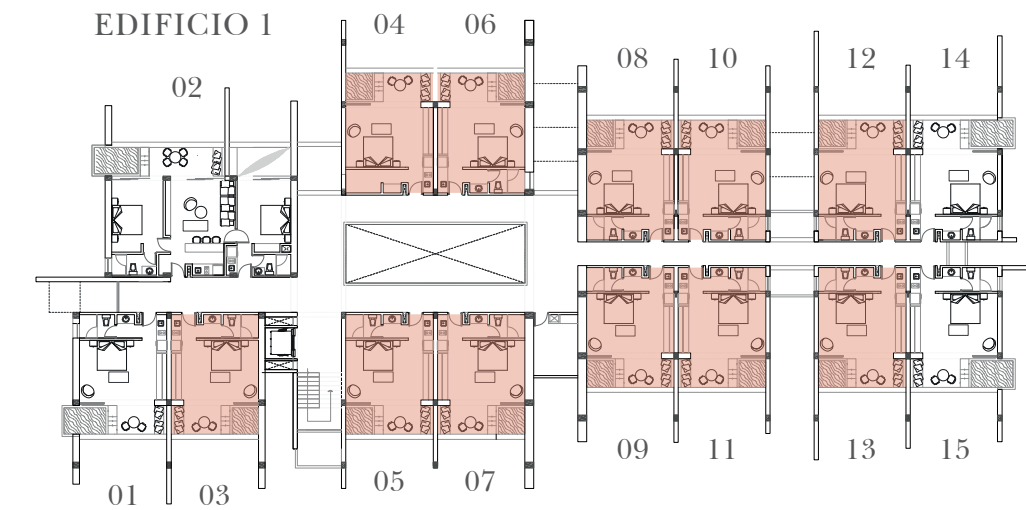
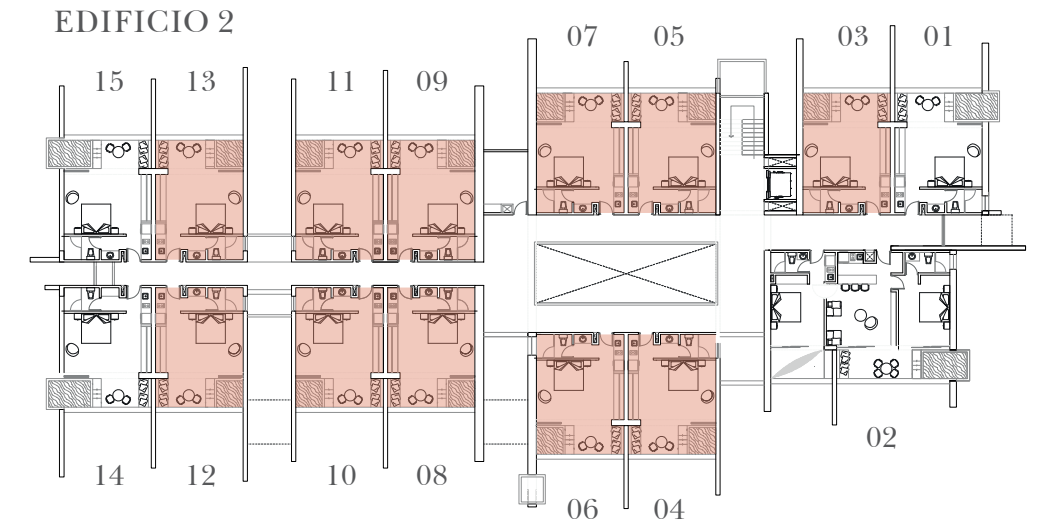



# TIPOLOGÍAS POR DEPARTAMENTO / APARMENT TYPOLOGIES

Edificio 1 y 2 | Nivel 2, 3 y 4 / Building 1 & 2 | 2nd, 3rd & 4th level

ÁREA INTERIOR / INDOOR AREA  
**39.69 M2**

ÁREA TERRAZA / TERRACE AREA  
**16.6 M2**

ÁREA TOTAL / TOTAL AREA  
**56.29 M2**



# Tipo B

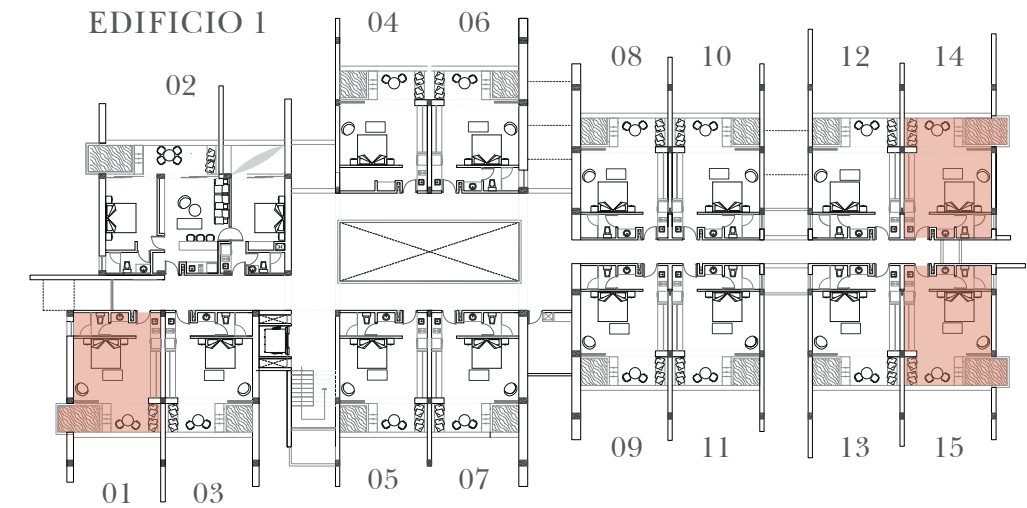
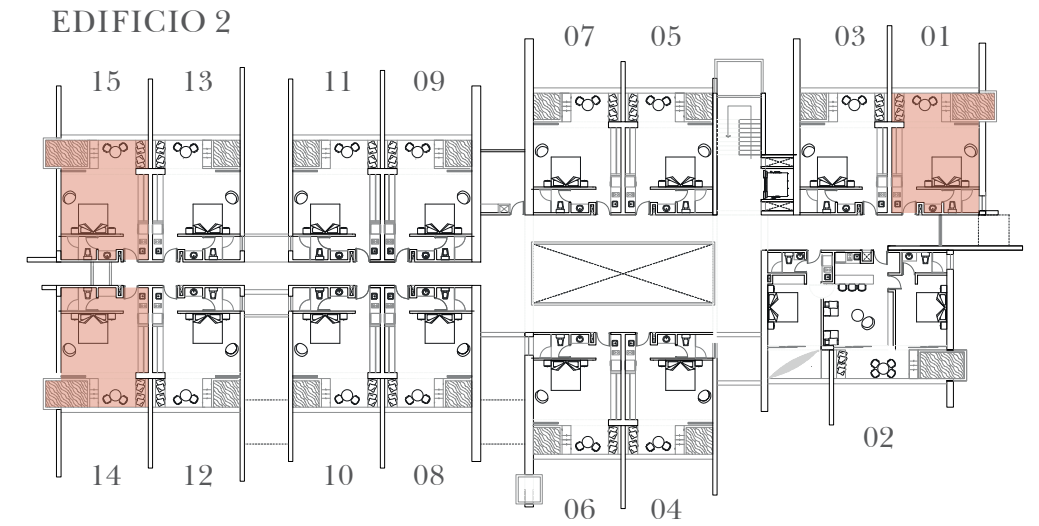



















# TIPOLOGÍAS POR DEPARTAMENTO / APARMENT TYPOLOGIES

Edificio 1 y 2 | Nivel 1 / Building 1 & 2 | 1st level

ÁREA INTERIOR / INDOOR AREA  
**87.28 M2**

ÁREA TERRAZA / TERRACE AREA  
**35.84 M2**

ÁREA TOTAL / TOTAL AREA  
**123.12 M2**



**2**



**1**



**1**



**2**



**2**



**2**



**1**

*Garden* **C**

EDIFICIO 2

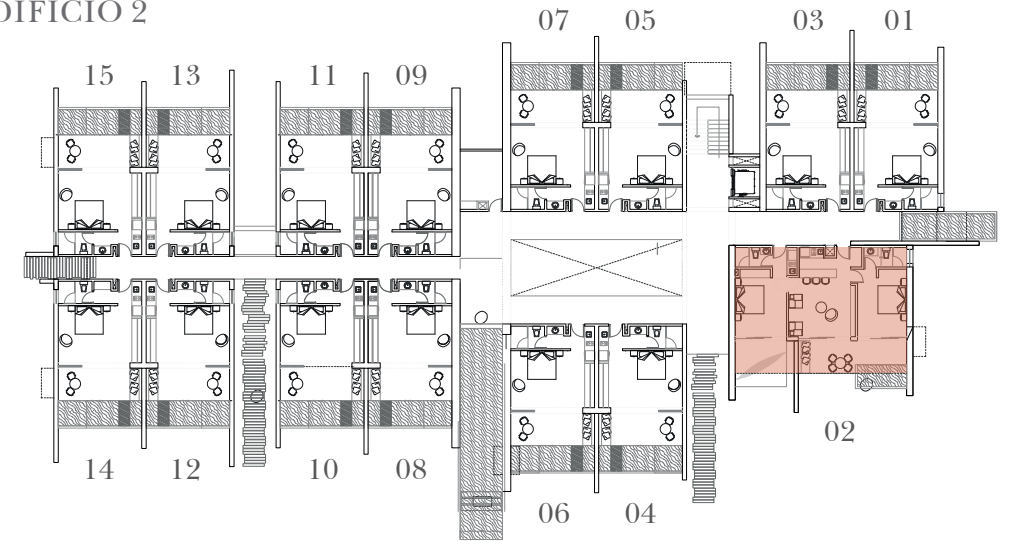

EDIFICIO 1

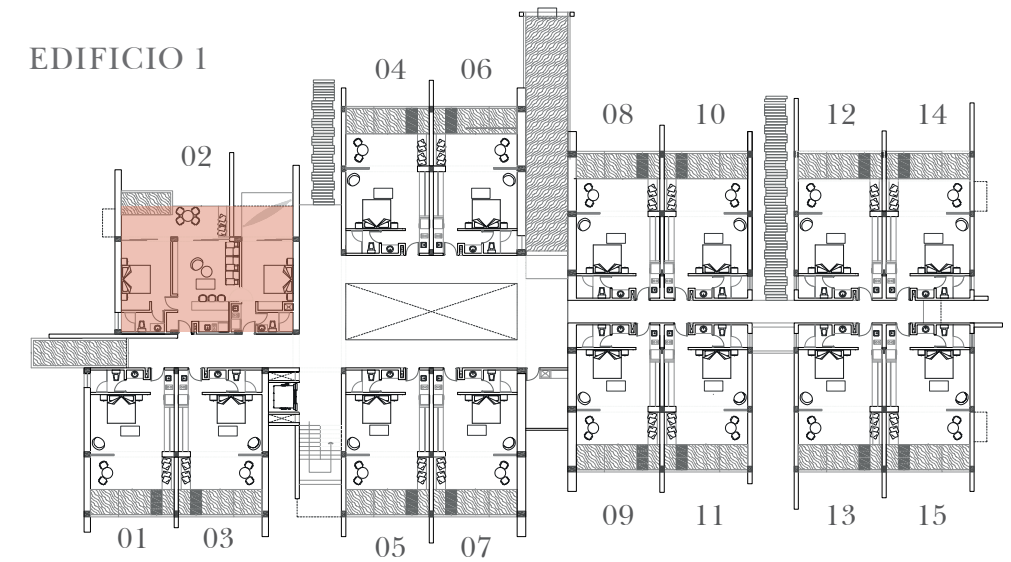



# TIPOLOGÍAS POR DEPARTAMENTO / APARMENT TYPOLOGIES

Edificio 1 y 2 | Nivel 2, 3 y 4 / Building 1 & 2 | 2nd, 3rd & 4th level

ÁREA INTERIOR / INDOOR AREA  
**82.35 M2**

ÁREA TERRAZA / TERRACE AREA  
**31.4 M2**

ÁREA TOTAL / TOTAL AREA  
**113.75 M2**

## Tipo C



2



2



1



2



1



1



1

EDIFICIO 2

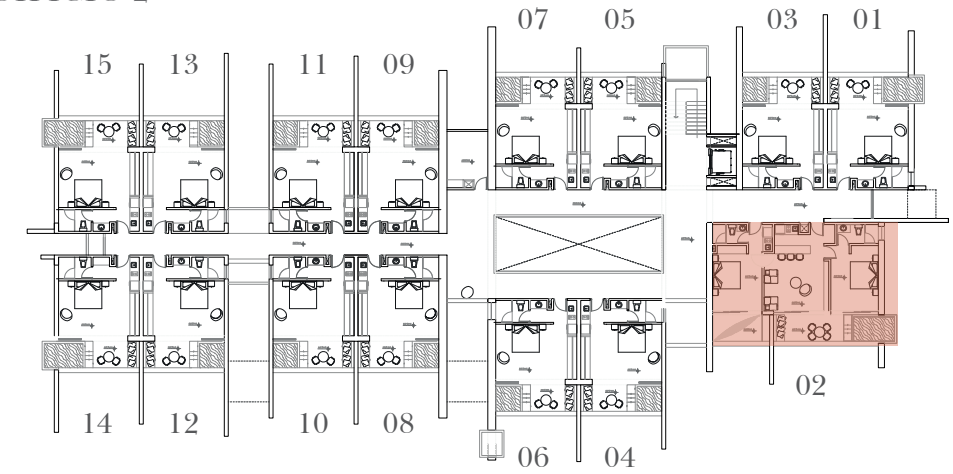

EDIFICIO 1

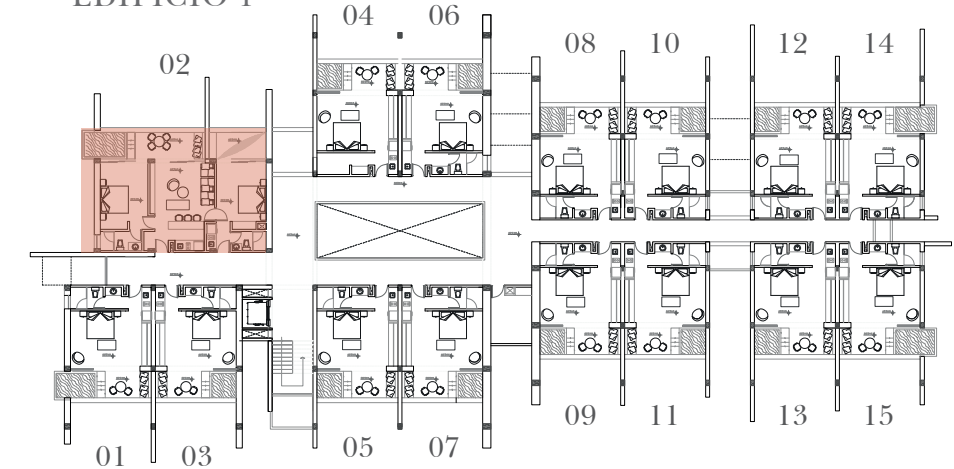



















# AMENIDADES / AMENITIES





Piscina “espejo” / “Mirror” pool













Piscina infinita / Infinity pool

















---

DESARROLLADOR

---

RIVIERA REALTY®

Desarrolladora de conceptos inmobiliarios que nace en la Riviera Maya; nuestro objetivo es crear proyectos creativos enfocados en ofrecer un excelente estilo de vida.

La innovación constante en el rubro de la hospitalidad es lo que nos motiva a generar opciones de inversión que gracias a su estabilidad física y financiera se conviertan en un refugios del capital de nuestros clientes.

Nuestra visión está enfocada en reinventar las formas de invertir en el sector inmobiliario de la Riviera Maya a través de la aplicación de nuevas tecnologías que permitan a los inversionistas un excelente Retorno de Inversión (ROI).

Real estate concepts developer born in the Riviera Maya; our goal is to generate creative projects focused on offering an excellent lifestyle.

Constant innovation in hospitality is what motivates us to create investment options that become the refuge or our client's capital thanks to their physical and financial stability.

Our vision is focused on reinventing the investing ways in the real state sector of the Riviera Maya through the application of new technologies that allow investors an excellent Return on Investment (ROI).







# RIVIERAÉLTY

Bienvenidos al lado más  
artístico de Rivieralty.